

## BF SERIES

### Hot Water cylinders with extractable Heat exchanger

Elbi Flanged cylinders with extractable stainless steel heat exchangers are suitable for the production of DHW in commercial and industrial applications. (e.g. condos, hospitals, sport centres, gyms, campsites, pools, etc. ).

Applications using ELBI BF range of cylinders require heat sources that are less in power than that required by instantaneous water heaters because the DHW is stored in the cylinders and available on demand (slow recovery rate).

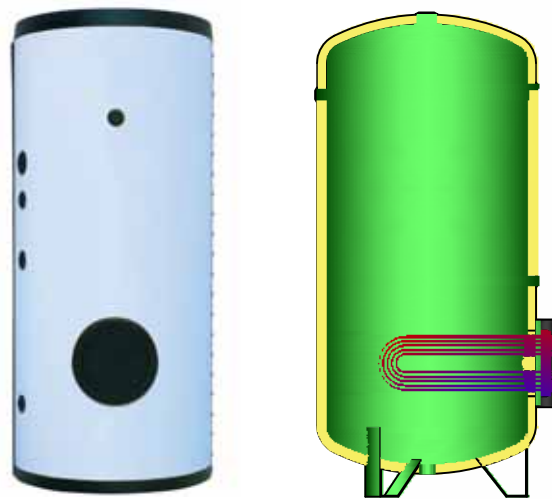

ELBI BF cylinders are available with up to 3 heat exchangers. These cylinders are supplied in capacity ranging from 1500 to 5000 litres.

The BF cylinders can be installed with:

- o Boilers
- o Vapour heating systems
- o Solar systems

The **extractable heat exchanger** is a U-shaped bundle of pipes also known as battery. It is manufactured internally in AISI 304 stainless steel. The fluid passing through it can be either heated water or steam. The working conditions in the primary heated water shall not exceed those indicated in the technical features paragraph.

The **TOP-PRO®** internal coating is suitable for use in contact with the DHW and avoids corrosion to occur in the cylinder. These cylinders are supplied with **Magnesium Anode**. **Impressed current** anodes are supplied on demand.

ELBI BF cylinders come with CFC and HCFC-free 50 mm. **insulation** and white RAL 9016 PVC external finish.

**Warranty: 3 years**

## Technical Features

### Cylinder

- Capacity : **1500 / 2000 / 3000 / 5000** litre;
- Maximum Working Pressure: **6 bar**;
- Maximum Working Temperature: **95°C**;
- Fluid: Domestic Hot Water (DHW).

### Heat Exchangers

- Fluid: Heated Water (from Boiler)
  - Surface: 1.6/ 2.5/ 3.0 / 4.0/ 5.0 / 6.0/ 10.0 Sq. Mt.;
  - Maximum Working Pressure: **12 bar**;
  - Maximum Working Temperature: **110°C**
- Fluid: Saturated steam: 1.6 / 2.5 Sq. Mt.;
  - Maximum Working Pressure: **4 bar**;
  - Maximum Working Temperature: **152°C**
- Fluid: Saturated steam: 3.0 – 10.0 Sq. Mt.
  - Maximum Working Pressure: **2 bar**;
  - Maximum Working Temperature: **134°C**.

**ELBI BF cylinders are manufactured to PED 97/23/EC. The fluid passing through each heat exchanger can be either heated water or saturated vapor. If the fluid temperature exceeds 100°C special gaskets shall be ordered with the cylinder.**

### Insulation

- Material: Expanded open cells polyurethane. Thickness: 50 mm.;
- Thermal Conductivity 39 mW/mK;
- External finish : PVC white colour RAL 9016.

## Dimensional information

MOD.	Litre	S1 m <sup>2</sup>	S2 m <sup>2</sup>	S3 m <sup>2</sup>	S1 litre	S2 litre	S3 litre	Ds mm	Dc mm	H mm	A mm	B mm	C mm	E mm	F mm	G mm	L mm	M mm	N mm
<b>BF-1</b>	1500	3	-	-	15	-	-	1000	1100	2445	500	555	780	1085	-	-	-	-	2020
	2000	4	-	-	18	-	-	1100	1200	2415	470	525	750	1055	-	-	-	-	1990
	3000	6	-	-	24	-	-	1250	1350	2770	515	550	775	1080	-	-	-	-	2315
	5000	10	-	-	39	-	-	1600	1700	2920	600	635	860	1165	-	-	-	-	2400
<b>BF-2</b>	1500	4	3	-	18	15	-	1000	1100	2445	500	555	780	-	1085	1310	-	-	2020
	2000	4	4	-	18	18	-	1100	1200	2415	470	525	750	-	1055	1280	-	-	1990
	3000	6	6	-	24	24	-	1250	1350	2770	515	550	775	-	1080	1305	-	-	2315
	5000	10	10	-	39	39	-	1600	1700	2920	600	635	860	-	1165	1390	-	-	2400
<b>BF-3</b>	1500	4	3	1.6	18	15	7.5	1000	1100	2445	500	555	780	-	1085	1310	1685	1855	2020
	2000	4	4	2.5	18	18	12.5	1100	1200	2415	470	525	750	-	1055	1280	1655	1825	1990
	3000	6	6	3	24	24	15	1250	1350	2770	515	550	775	-	1080	1305	1800	2025	2315
	5000	10	10	5	39	39	21	1600	1700	2920	600	635	860	-	1165	1390	1935	2160	2400

**DN1-DN2** : Primary flow from / return to boiler; **DN3-DN4** : Primary flow from / return to boiler; **DN5** : Mains water supply; **DN6** : Hot water draw-off; **DN7** : Magnesium Anode; **DN8**: controls (Thermometer, Thermostat); **DN9** : Drain; **DN10**: Safety devices; **DN11**: Circulation

## Serie BF-1

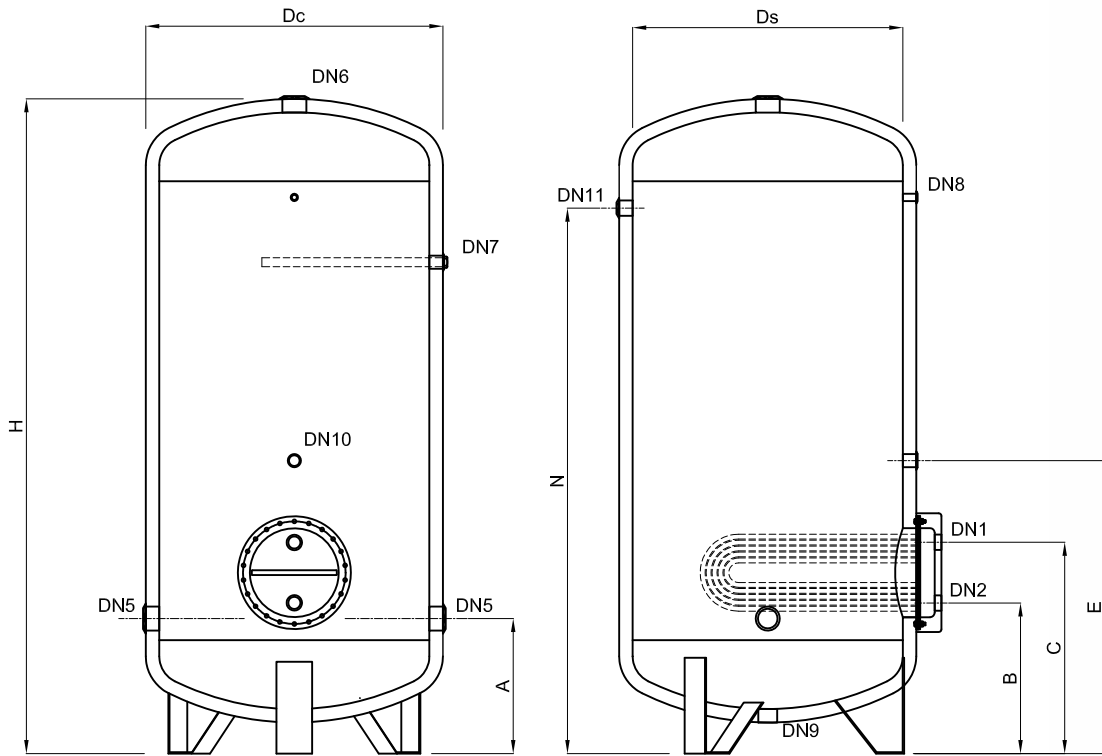

## Serie BF-2

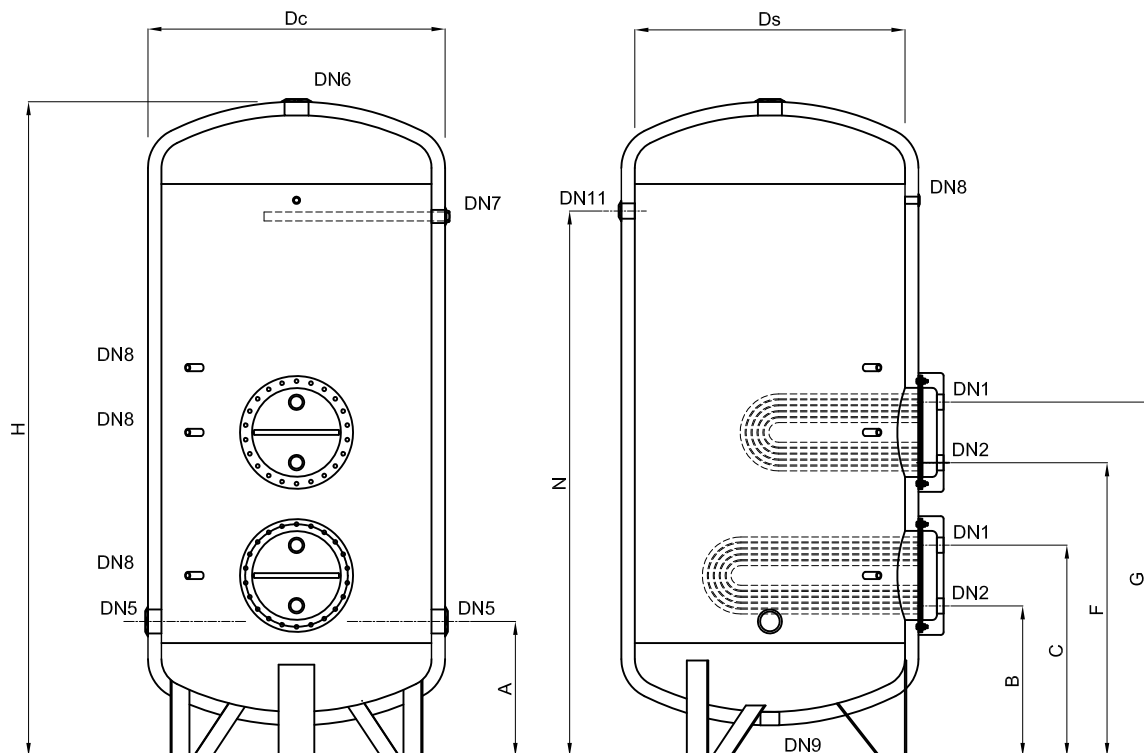

## Serie BF-3

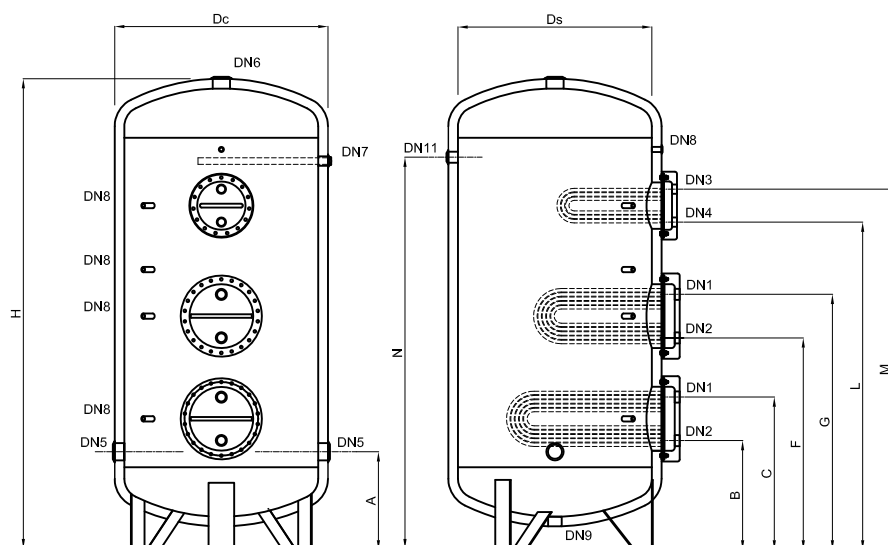

## Technical information

ELBI BF cylinders are selected in relation to the DHW requirements from the users. For correct sizing see on page 5.

### Safety devices:

In order to avoid overpressure in the cylinder the following control and safety devices shall be installed:

- DHW circuit:
  - Safety valve set at pressure below the cylinder maximum working pressure;
  - ELBI DV series expansion vessel. The sizing chart below is applicable under the following working conditions: Maximum hot water temp. 85°C / Mains Water 15°C / Vessel precharge pressure: 3 bar / Safety Valve: 6 bar

Model	ELBI DV series expansion vessel
BF-1 BF-2 BF-3	1500 DV – 150
BF-1 BF-2 BF-3	2000 DV – 150
BF-1 BF-2 BF-3	3000 DV – 300
BF-1 BF-2 BF-3	5000 n°2 DV – 200

**Magnesium Anode :**

Model	Dimensions
1500 - 2000	1.1/4" x 670
3000	1.1/4" x 700
5000	1.1/2" x 690

**Installation Example # 1 (BF-1 cylinder with heated water from boiler):**

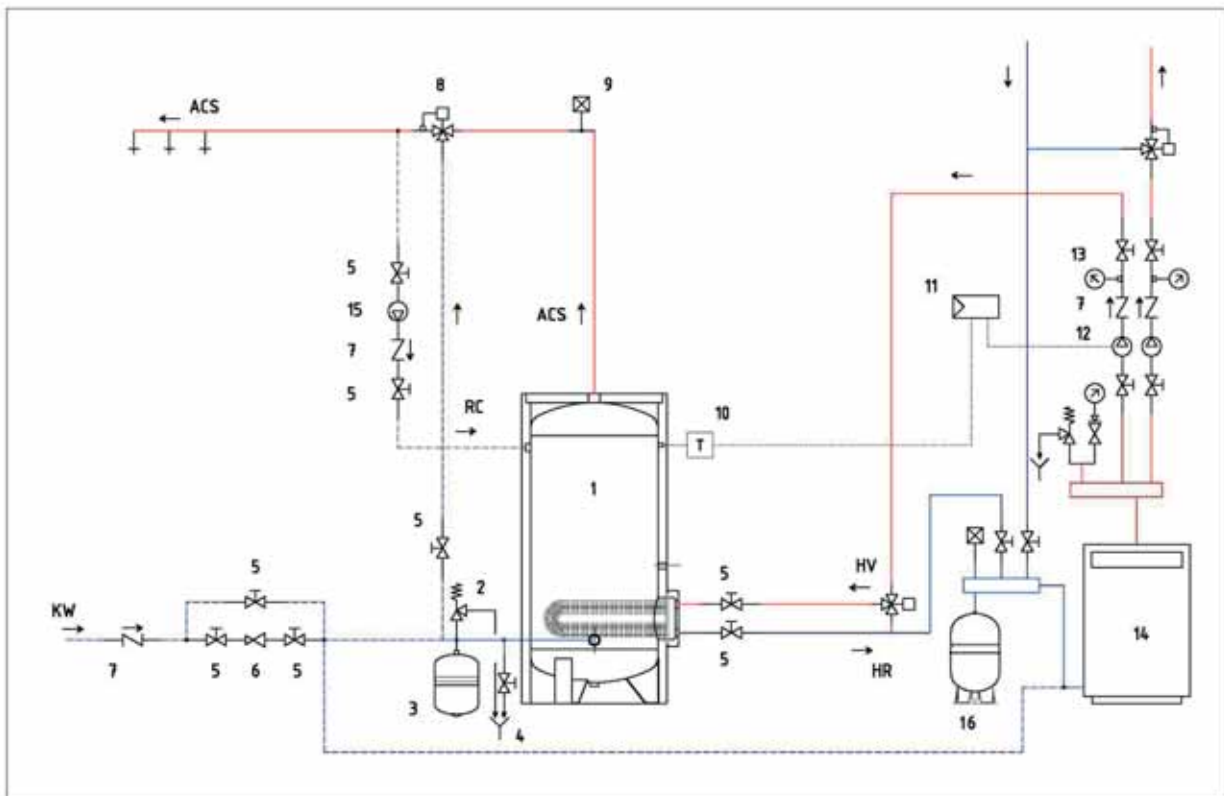

- 1 BF-1 cylinder
- 2 Safety Valve
- 3 ELBI DV series expansion vessel
- 4 Drain
- 5 Isolating Valve
- 6 Pressure reducing valve
- 7 Check Valve
- 8 Mixing Valve
- 9 Purge
- 10 Thermometer
- 11 Control Panel

- 12 Circulator Pump
- 13 Thermometer
- 14 Boiler
- 15 DHW circulation Pump
- 16 ERCE series expansion vessel

- DHW Hot water draw off
- KW Mains water supply
- RC Circulation
- HV Flow from Boiler
- HR Return to Boiler

Installation Example # 2 (BF-2 cylinder: lower heat exchanger - solar circuit;  
upper heat exchanger - boiler):

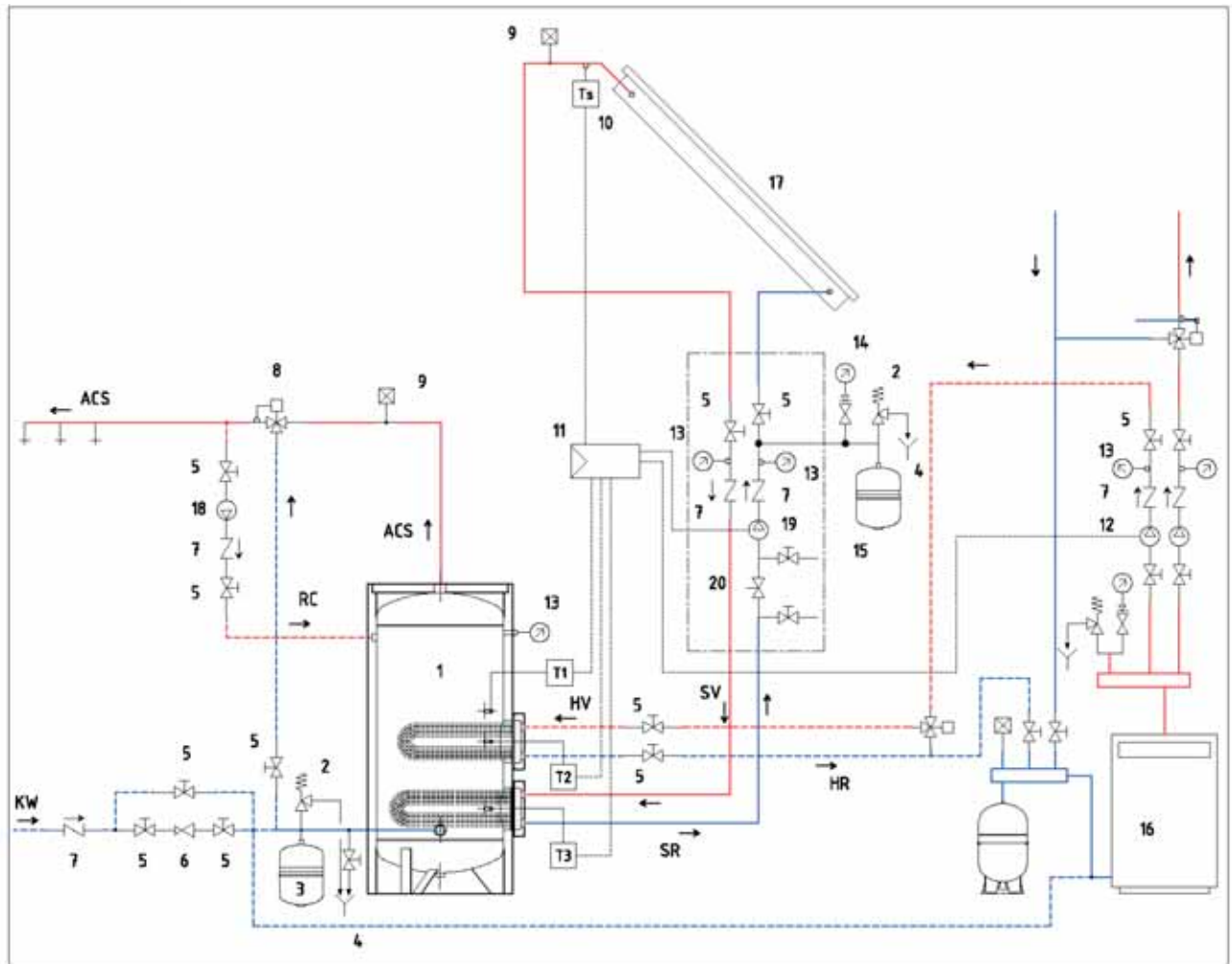



**Installation Example # 3 (BF-3 cylinder: lower and middle heat exchanger – solar circuit; Upper heat exchanger boiler):**

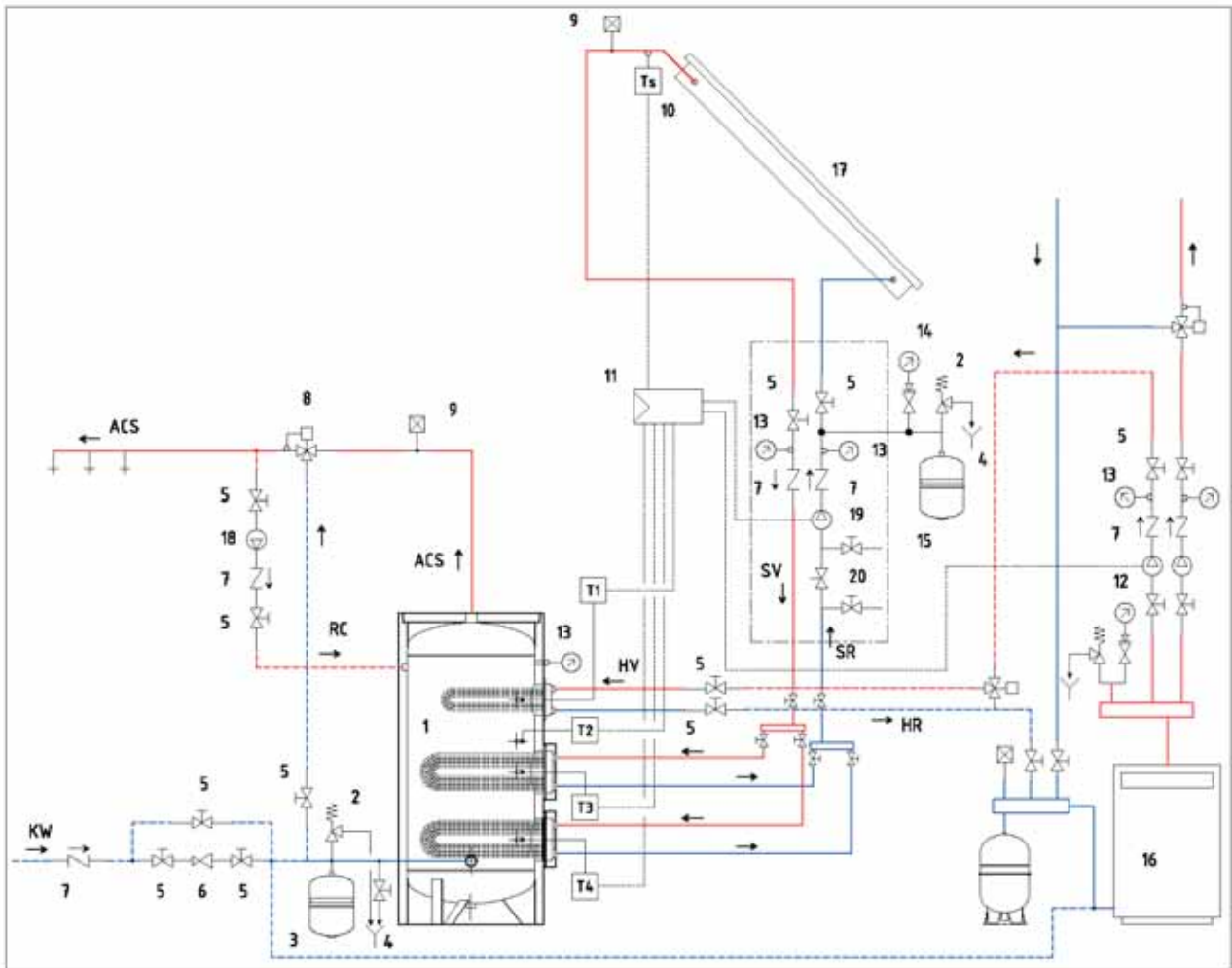

- 1 BF-2/ BF-3 cylinder
- 2 Safety Valve
- 3 ELBI DV series expansion vessel
- 4 Drain
- 5 Isolating Valve
- 6 Pressure reducing valve
- 7 Check Valve
- 8 Mixing Valve
- 9 Purge
- 10 Probe
- 11 Control Panel
- 12 Circulator pump
- 13 Thermometer
- 14 Pressure Gauge
- 15 ELBI DS series expansion vessel

- 16 Boiler
- 17 Solar Panel
- 18 DHW Circulation Pump
- 19 Solar circuit Pump
- 20 Fill-in Valve
- DHW Domestic Hot Water
- KW Mains Water supply
- RC Circulation
- HV Flow from Boiler
- HR Return to Boiler
- SV Flow from solar panel
- SR Return to solar panel
- T<sub>1</sub> T<sub>2</sub> Probes
- T<sub>3</sub> T<sub>4</sub> Probes
- Performances

## Performances

Heat exchanger with heated water passing through it at  $T_i = 80^\circ\text{C}$  ( $\Delta T=10^\circ\text{C}$ ).  
Maximum hot water temperature  $60^\circ\text{C}$ ; Mains Water supply temperature  $15^\circ\text{C}$ ,

Model	Heat Exchanger (m <sup>2</sup> )	Power (1)(2) (kW)	Pump capacity (litre/H)	Heating time (3) (min.)	DHW at $60^\circ\text{C}$ (litre/H)	First 10 min, Production of water at $45^\circ\text{C}$ (litre) <sup>(4)</sup>
BF1 - 1500	3.0	72.00	6400	70	1375	1243
BF1 - 2000	4.0	98.00	8500	63	1828	1594
BF1 - 3000	6.0	159.30	14100	58	3044	2524
BF1 - 5000	10.0	250.70	22000	62	4790	4085

(1) primary flow @  $80^\circ\text{C}$  primary return @  $70^\circ\text{C}$ ;  
(2) Mains Water supply @  $15^\circ\text{C}$ ;  
(3) Heating time from  $15^\circ\text{C}$  to  $60^\circ\text{C}$ ;  
(4) Domestic Hot Water available @  $45^\circ\text{C}$  in the first 10 minutes of water draw-off from stored water @  $60^\circ\text{C}$ ,

Heat exchanger with heated water passing through it at  $T_i = 80^\circ\text{C}$  ( $\Delta T=10^\circ\text{C}$ ). with  
Maximum hot water temperature  $45^\circ\text{C}$ ; Mains Water supply temperature  $15^\circ\text{C}$ ,

Model	Heat Exchanger (m <sup>2</sup> )	Power (1)(2) (kW)	Pump capacity (litre/H)	Heating time (3) (min.)	DHW at $45^\circ\text{C}$ (litre/H)
BF1 - 1500	3.0	92.00	8100	37	2635
BF1 - 2000	4.0	131.60	11600	31	3770
BF1 - 3000	6.0	223.60	19710	28	6410
BF1 - 5000	10.0	339.00	29900	31	9720

(1) primary flow @  $80^\circ\text{C}$  primary return @  $70^\circ\text{C}$ ;  
(2) Mains Water supply @  $15^\circ\text{C}$ ;  
(3) Heating time from  $15^\circ\text{C}$  to  $45^\circ\text{C}$ ;

Heat exchanger with heated water passing through it at  $T_i = 80^\circ\text{C}$  ( $\Delta T=10^\circ\text{C}$ ).  
Maximum hot water temperature  $60^\circ\text{C}$  and Mains Water supply temperature at  $15^\circ\text{C}$ ,

Model	Heat Exchanger (m <sup>2</sup> )	Power (1)(2) (kW)	Pump capacity (litre/H)	Heating time (3) (min.)	DHW at $60^\circ\text{C}$ (litre/H)	First 10 min, Production of water at $45^\circ\text{C}$ (litre) <sup>(4)</sup>
BF2-1500	3.0	72.00	6400	30	3203	1822
	4.0	98.00	8500			
BF2-2000	4.0	98.00	8500	32	3656	2230
	4.0	98.00	8500			
BF2-3000	6.0	159.30	14100	29	6088	3607
	6.0	159.30	14100			
BF2-5000	10.0	250.70	22000	31	9580	5715
	10.0	250.70	22000			

(1) primary flow @  $80^\circ\text{C}$  primary return @  $70^\circ\text{C}$ ;  
(2) Mains Water supply @  $15^\circ\text{C}$ ;  
(3) Heating time from  $15^\circ\text{C}$  to  $60^\circ\text{C}$ ;  
(4) Domestic Hot Water available @  $45^\circ\text{C}$  in the first 10 minutes of water draw-off from stored water @  $60^\circ\text{C}$ ,



**Heat Exchangers with heated water passing through it at  $T_i = 80^\circ\text{C}$  ( $\Delta T=10^\circ\text{C}$ ).  
Maximum hot water temperature  $45^\circ\text{C}$ ; Mains Water supply temperature  $15^\circ\text{C}$ ,**

Model	Heat Exchanger (m <sup>2</sup> )	Power (1)(2) (kW)	Pump capacity (litre/H)	Heating time (3) (min.)	DHW at $45^\circ\text{C}$ (litre/H)
BF2-1500	3.0	92.00	8100	16	6135
	4.0	131.60	11600		
BF2-200	4.0	131.60	11600	16	7540
	4.0	131.60	11600		
BF2-3000	6.0	223.60	19710	14	12820
	6.0	223.60	19710		
BF2-5000	10.0	339.00	29900	16	19440
	10.0	339.00	29900		

(1) primary flow @  $80^\circ\text{C}$  primary return @  $70^\circ\text{C}$ ;  
(2) Mains Water supply @  $15^\circ\text{C}$ ;  
(3) Heating time from  $15^\circ\text{C}$  to  $45^\circ\text{C}$ ;

**Heat exchangers with heated water passing through it at  $T_i = 80^\circ\text{C}$  ( $\Delta T=10^\circ\text{C}$ ).  
Maximum hot water temperature  $60^\circ\text{C}$ ; Mains Water supply temperature  $15^\circ\text{C}$ ,**

Model	Heat Exchanger (m <sup>2</sup> )	Power (1)(2) (kW)	Pump capacity (litre/H)	Heating time (3) (min.)	DHW at $60^\circ\text{C}$ (litre/H)	First 10 min. Production of water at $45^\circ\text{C}$ (litre) <sup>(4)</sup>
BF3-1500	1.6	40.60	3580	42	775	1084
	3.0	72.00	6400	30	3203	1825
	4.0	98.00	8500			
BF3-2000	2.5	54.00	4760	38	1030	1362
	4.0	98.00	8500	32	3656	2220
	4.0	98.00	8500			
BF3-3000	3.0	72.00	6400	46	1375	1895
	6.0	159.30	14100	29	6088	3592
	6.0	159.30	14100			
BF3-5000	5.0	115.00	10150	47	2197	3228
	10.0	250.70	22000	31	9580	5705
	10.0	250.70	22000			

(1) primary flow @  $80^\circ\text{C}$  primary return @  $70^\circ\text{C}$ ;  
(2) Mains Water supply @  $15^\circ\text{C}$ ;  
(3) Heating time from  $15^\circ\text{C}$  to  $60^\circ\text{C}$ ;  
(4) Domestic Hot Water available @  $45^\circ\text{C}$  in the first 10 minutes of water draw-off from stored water @  $60^\circ\text{C}$ ,

Heat exchanger with heated water passing through it at  $T_i = 80^\circ\text{C}$  ( $\Delta T=10^\circ\text{C}$ ).  
Maximum hot water temperature  $45^\circ\text{C}$ ; Mains Water supply temperature  $15^\circ\text{C}$ ,

Model	Heat Exchanger (m <sup>2</sup> )	Power (1)(2) (kW)	Pump capacity (litre/H)	Heating time (3) (min.)	DHW at $45^\circ\text{C}$ (litre/H)
BF3-1500	1.6	59.20	5230	20	1690
	3.0	92.00	8100	16	6135
	4.0	131.60	11600		
BF3-2000	2.5	78.00	6900	18	2230
	4.0	131.60	11600	16	7540
	4.0	131.60	11600		
BF3-3000	3.0	91.90	8140	24	2635
	6.0	223.60	19710	14	12820
	6.0	223.60	19710		
BF3-5000	5.0	160.00	14000	23	4580
	10.0	339.00	29900	16	19440
	10.0	339.00	29900		

(1) primary flow @  $80^\circ\text{C}$  primary return @  $70^\circ\text{C}$ ;  
(2) Mains Water supply @  $15^\circ\text{C}$ ;  
(3) Heating time from  $15^\circ\text{C}$  to  $45^\circ\text{C}$ ;

Heat exchanger with saturated Vapour passing through it at  $T_i = 120^\circ\text{C}$  (1 bar).  
Maximum hot water temperature  $60^\circ\text{C}$  e Mains Water supply temperature  $15^\circ\text{C}$ ,

Model	Heat Exchanger (m <sup>2</sup> )	Power (1) (kW)	Vapour flow (kg/H)	Heating time (2) (min.)	DHW at $60^\circ\text{C}$ (litre/H)	First 10 min. Production of water at $45^\circ\text{C}$ (litre) <sup>(4)</sup>
BF1 - 1500	3.0	236.00	400	21	4600	2070
BF1 - 2000	4.0	287.00	486	22	5575	2470
BF1 - 3000	6.0	440.00	745	21	8400	3820
BF1 - 5000	10.0	675.00	1143	23	12890	6020

(1) Mains Water supply @  $15^\circ\text{C}$ ;  
(2) Heating time from  $15^\circ\text{C}$  to  $60^\circ\text{C}$ ;  
(3) Domestic Hot Water available @  $45^\circ\text{C}$  in the first 10 minutes of water draw-off from stored water @  $60^\circ\text{C}$ ,

Heat exchanger with saturated Vapour passing through it at  $T_i = 120^\circ\text{C}$  (1 bar).  
Maximum hot water temperature  $45^\circ\text{C}$ ; Mains Water supply temperature  $15^\circ\text{C}$ ,

Model	Heat Exchanger (m <sup>2</sup> )	Power (1) (kW)	Vapour flow (kg/H)	Heating time (2) (min.)	DHW at $45^\circ\text{C}$ (litre/H)
BF1 - 1500	3.0	265.60	450	13	7615
BF1 - 2000	4.0	315.70	534	14	9048
BF1 - 3000	6.0	495.00	839	13	14185
BF1 - 5000	10.0	745.00	1263	14	21350

(1) Mains Water supply @  $15^\circ\text{C}$ ;  
(2) Heating time from  $15^\circ\text{C}$  to  $45^\circ\text{C}$ ;

Heat exchanger with saturated Vapour passing through it at = 134°C (2 bar).  
 Maximum hot water temperature 60°C; Mains Water supply temperature 15°C,

Model	Heat Exchanger (m <sup>2</sup> )	Power (1) (kW)	Vapour flow (kg/H)	Heating time (2) (min.)	DHW at 60°C (litre/H)	First 10 min. Production of water at 45°C (litre) <sup>(4)</sup>
BF1 - 1500	3.0	278.00	479	19	5310	2265
BF1 - 2000	4.0	338.00	583	18	6458	2729
BF1 - 3000	6.0	525.00	905	18	10030	4537
BF1 - 5000	10.0	790.00	1362	20	15095	6380

(1) Mains Water supply @ 15°C;  
 (2) Heating time from 15°C to 60°C;  
 (3) Domestic Hot Water available @ 45°C in the first 10 minutes of water draw-off from stored water @ 60°C,

Heat exchanger with Saturated Vapour passing through it at T<sub>i</sub> = 134°C (2 bar).  
 Maximum hot water temperature 45°C; Mains Water supply temperature 15°C,

Model	Heat Exchanger (m <sup>2</sup> )	Power (1) (kW)	Vapour flow (kg/H)	Heating time (2) (min.)	DHW at 45°C (litre/H)
BF1 - 1500	3.0	306.30	528	11	8780
BF1 - 2000	4.0	369.20	636	11	10580
BF1 - 3000	6.0	645.00	1112	10	18485
BF1 - 5000	10.0	820.00	1415	13	23500

(1) Mains Water supply @ 15°C;  
 (2) Heating time from 15°C to 45°C;

Maximum Pressure drop:

Heat exchanger Sq. Mt.	Pressure Drop mbar
1.60	80
2.50	110
3.00	200
4.00	220
5.00	270
6.00	350
10.00	400